



Box Plus

Box Plus



MACCHINA PIEGA-INCOLLATRICE **BOX PLUS**

Macchina di nuova costruzione, made in Italy, creata per la realizzazione di:

1. Astucci lineari
2. Piega-incolla di shopper bag in 2 passaggi
3. Applicazione di nastro biadesivo su locandine, buste, porta CD/DVD, scatole (opzionale su richiesta)
4. Inserzione di tessere, campionari in plastica, carta, DVD (opzionale su richiesta)

BOX PLUS macchina con alimentatore automatico **FEEDER PLUS** creata per la piegatura – incollatura di astucci lineari, shopper bag in due passaggi in per formare e chiudere il tubo della borsa. Box Plus applica anche nastro biadesivo su cartoncino o carta con l'alimentatore automatico in formato 720 x 1020 mm.



BOX PLUS FOLDING AND GLUING MACHINE

New construction machine, made in Italy, designed for the production of:

1. Linear boxes.
2. Folding and gluing shopper bags in 2 steps
3. Apply the double-sided tape on poster, envelopes, DVD wallets, boxes (optional on request)
4. Inserting cards, plastic samples, paper, DVD, (optional on request)

BOX PLUS is a machine with the automatic **FEEDER PLUS** designed for folding and gluing strait line boxes, shopper bags in two steps in order to form and close the tube of the bag. Box Plus can also apply the double sided tape on cardboard or paper with automatic feeder with the format 720 x 1020 mm in full automatic way.





■ ■ Doppio sistema di trasporto carta a cinghie per grammature leggere, o senza aspirazione per grammature più pesanti.

■ ■ *Dual transport system with suction belt for light weights or transport belts for heavier ones*

Caratteristiche tecniche



Formato di introduzione	Max 720 x 1020 mm Min 80 x 100 mm
Grammatura carta	Min 150 g/m ² Max 400 g/m ²
Capacità di carico carta	200 mm
Capacità di carico cartone	400 mm
N. di applicazioni	da 1 a 10
Lung. max di applicazione colla	999 mm
Aria Compressa	6 bar con connessione da 1/2 pollice
Velocità meccanica	120 Mt/m
Allacciamento elettrico	4 Kw, 380 V + N
Dimensioni macchina	4115 x 1294, h 1590 mm

Technical Characteristics



Introduction format	Max 720 x 1020 mm Min 80 x 100 mm
Paper weight	Min 150 g/m ² Max 400 g/m ²
Paper load capacity	200 mm
Cardboard load capacity	400 mm
N. di applicazioni	from 1 to 10
Max. length of glue application	999 mm
Compressed air	6 bar with 1/2 inch connection
Mechanical speed	120 Mt/m
Power connection	4 Kw, 380 V + N
Dimensions	4115 x 1294, h 1590 mm

Macchina predisposta per aggiungere n. 1 o 2 applicatori di nastro biadesivo RAP • Macchina predisposta per aggiungere un inserter • Sistema di messa a squadra mediante i due riscontri laterali. • N.2 Sistemi di trasporto carta. Bruchi Lunghi con pressione regolabile

Machine ready to add 1 or 2 Rap applicator of double sided tape • Machine ready to add one inserter • Athos plus has a fix register side system • N.2 main paper transport devices with transmission system, complete of small wheel "Wheeled thongs"

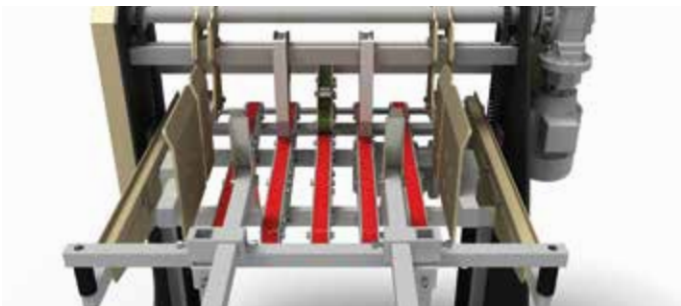

■ ■ Alimentatore continuo

■ ■ *Plus Feeder unique*

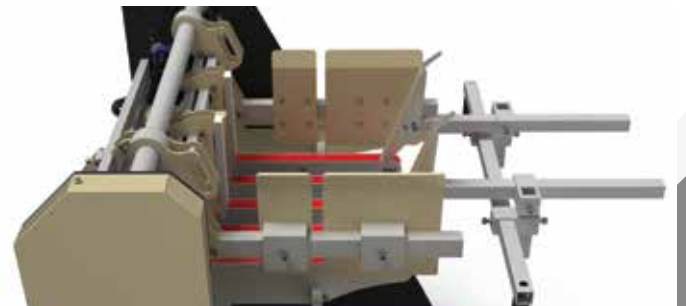

■ ■ Sistema di regolazione rapido per alimentazione.

■ ■ *Adjustment system for quick power tapes or power through carpets aspirants.*

■ ■ Prodotti realizzabili con la macchina Box Plus

■ ■ *Products achievable with the Box Plus machine*

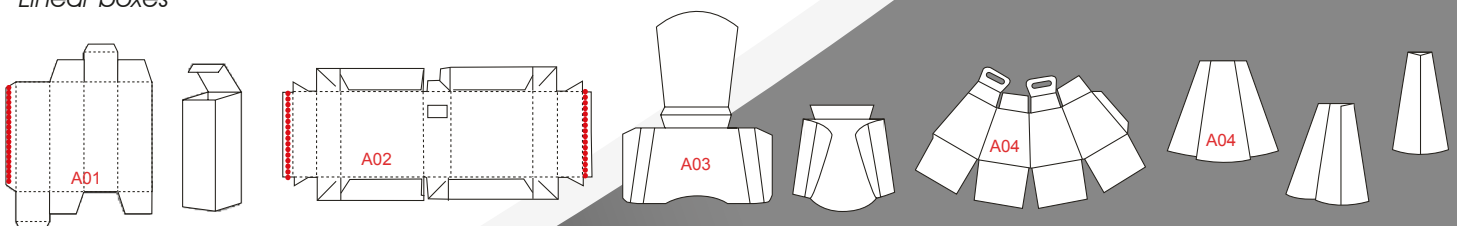

Astucci Lineare e fondo automatico
Linear boxes



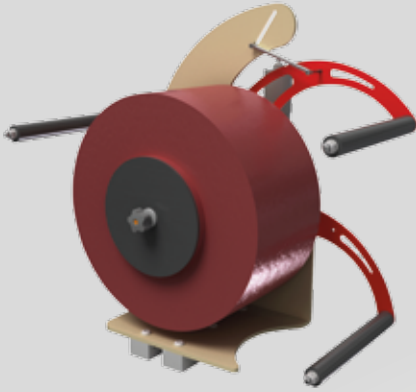

 **Opzionali su richiesta**

 **Optional on request**



 Applicatore nastro a strappo "RAP TEAR"
 **APPLICATOR "RAP Tear"** for applying the tear tape

 Applicatore nastro biadesivo "RAP"
 **Applicator of double-side tape "RAP"**

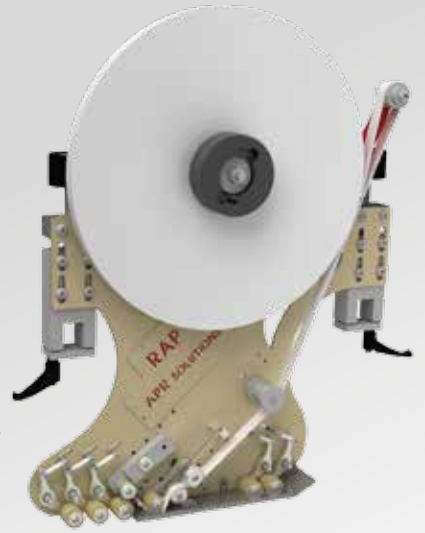

Specifiche tecniche Applicatore Rap	
Larghezza nastro min-max	Da 9mm-25mm Standard, a richiesta 50mm
Diam. max esterno Rotolo	480 mm
Diam. Rotolo	76 mm
Alimentazione	Elettro Pneumatica
Velocità max di produzione	120mt/min

Technical characteristics Rap	
Tape width min-max	From 9mm-25mm and on request up to 50 mm
Max outer diameter roll tape	480 mm
Internal diameter roll tape	76 mm
Power supply	Electro Pneumatics
Max. production speed	120 mt/min

 **Prodotti realizzabili con gli opzionali su richiesta**

 **Products achievable with the optional equipment**

Poster / Poster, Campionari Tessuti / Tissue samples, Buste / Envelopes, Sacchetti / Bags, Portaritratti per foto / Picture frames

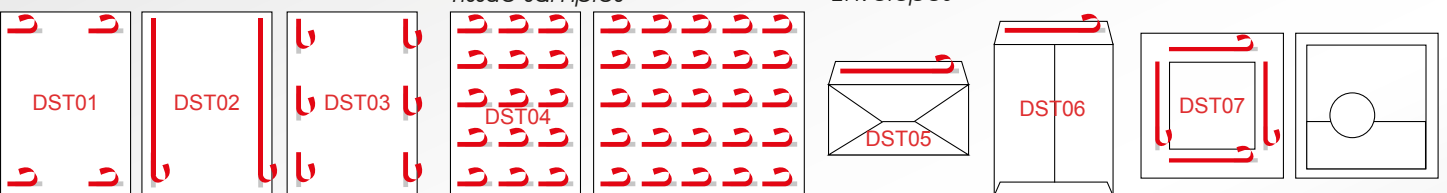

 **Prodotti realizzabili con l'INSERTER**

 **Products achievable with the INSERTER**

1° passaggio / 1st step, 2° passaggio / 2nd step

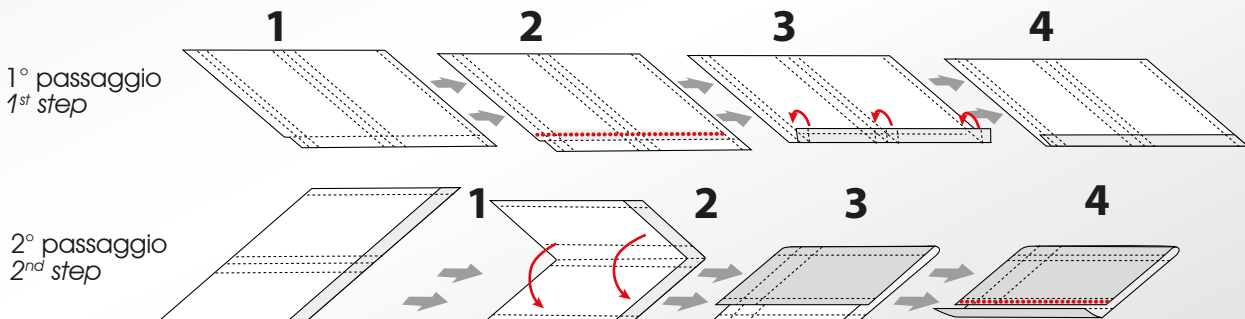

Shopper bag

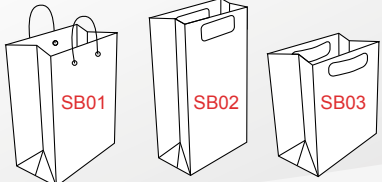

APR Solutions srl
 Via Aldo Moro, 10 • 10030 Rondissone TO - Italy
 Tel: +39 011 9182026 • Fax: +39 011 9182685
 Email: info@aprsolutions.com • Sito: www.aprsolutions.com